

Part Number: PU060-10016-P1

Kit Contents

Item #	Quantity Reqd.	Description
1	1	Front Passenger Side Mudguard
2	1	Front Driver Side Mudguard
3	1	Rear Passenger Side Mudguard
4	1	Rear Driver Side Mudguard
5	1	Hardware Kit (Front)
6	1	Hardware Kit (Rear)

Hardware Bag Contents

Item #	Quantity Reqd.	Description
Front (1 Bag, K2268)		
1	4	#14 x 19 mm Screw (Thick)
2	4	Push Pin
Rear (1 Bag, K2269)		
3	6	M5 x 20mm Screw (Thin)
4	4	Spring Clip (Small)
5	2	Spring Clip (Large)
6	4	Push Pin

Additional Items Required For Installation

Item #	Quantity Reqd.	Description
1		
2		
3		

Conflicts

Ground effects

Recommended Tools

Personal & Vehicle Protection	Notes
None	
Special Tools	Notes
None	
Installation Tools	Notes
Screwdriver	Phillips #2, #3
Drill/Angled Drill/90 Degree Drill Adaptor	
Drill Bit	6mm (1/4"), 8mm (5/16")
Socket Driver	10mm Socket
Clean Cloth/Rag	
Special Chemicals	Notes
Cleaner	Soap & water mixture

General Applicability

All models

Recommended Sequence of Application

Item #	Accessory
1	
2	
3	

*Mandatory

Vehicle Service Parts (may be required for reassembly)

Item #	Quantity Reqd.	Description
1		
2		
3		

Legend

 **STOP:** Damage to the vehicle may occur. Do not proceed until process has been complied with.

 **OPERATOR SAFETY:** Use caution to avoid risk of injury.

 **CAUTION:** A process that must be carefully observed in order to reduce the risk of damage to the accessory/vehicle and to ensure a quality installation.

 **TOOLS & EQUIPMENT:** Used in Figures calls out the specific tools and equipment recommended for this process.

 **REVISION MARK:** This mark highlights a change in installation with respect to previous issue.

 **SAFETY TORQUE:** This mark indicates that torque is related to safety.

Care must be taken when installing this accessory to ensure damage does not occur to the vehicle. The installation of this accessory should follow approved guidelines to ensure a quality installation.

These guidelines can be found in the "Accessory Installation Practices" document.

This document covers such items as:-

- Vehicle Protection (use of covers and blankets, cleaning chemicals, etc.).
- Safety (eye protection, rechecking torque procedure, etc.).
- Vehicle Disassembly/Reassembly (panel removal, part storage, etc.).
- Electrical Component Disassembly/Reassembly (battery disconnection, connector removal, etc.).

Please see your Toyota dealer for a copy of this document.

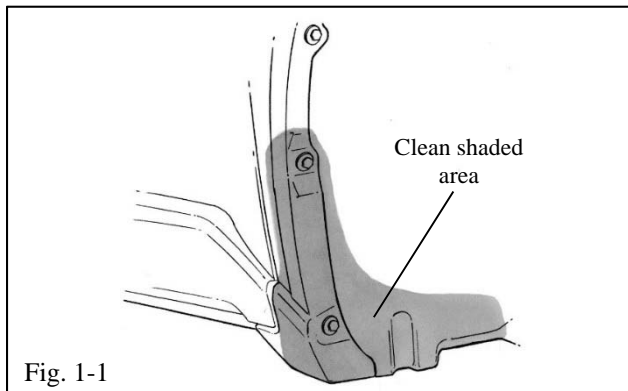

1. Clean the Front Mounting Area.

-  (a) Clean and degrease the front body panel where the mudguard will be located with a clean cloth and soap/water mixture (Fig. 1-1).

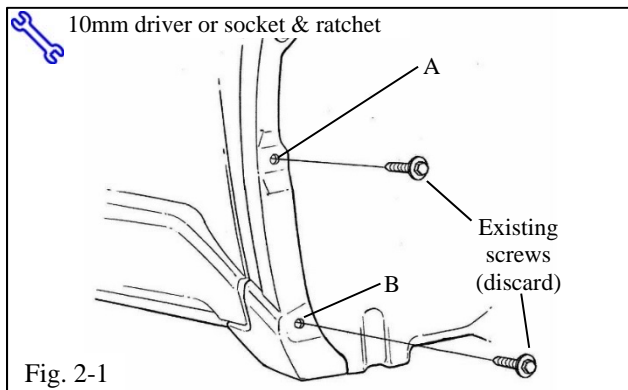

2. Remove the Front Hardware.

- (a) Remove and discard the existing screws at locations A and B (Fig. 2-1).

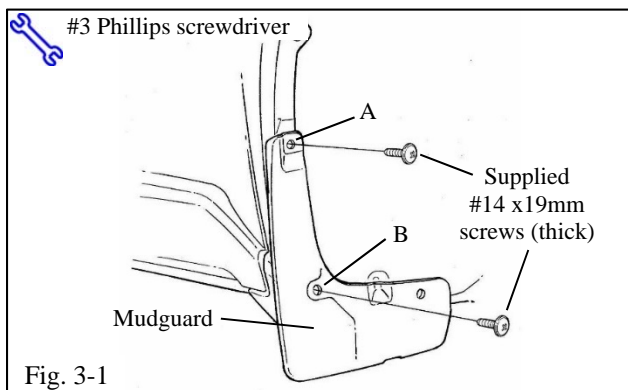

3. Install the Front Mudguard.

-  (a) While holding the part up and into body panel, mount the mudguard on the body panel and install the supplied #14 x 19 mm (thick) screws in locations A and B, then tighten (Fig. 3-1). Do not overtighten the screws.

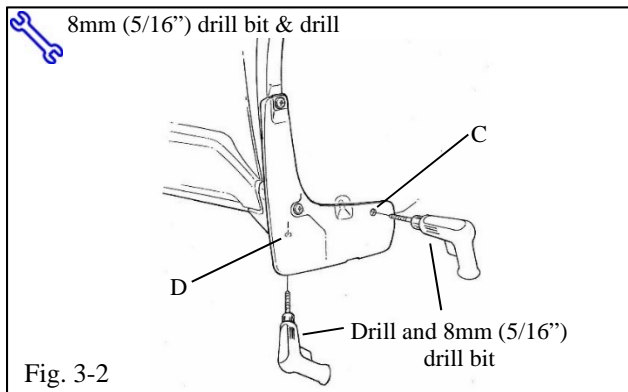

! (b) While holding the part up and into body panel, use the part as a template to drill 8mm (5/16") holes in locations C and D (Fig. 3-2).

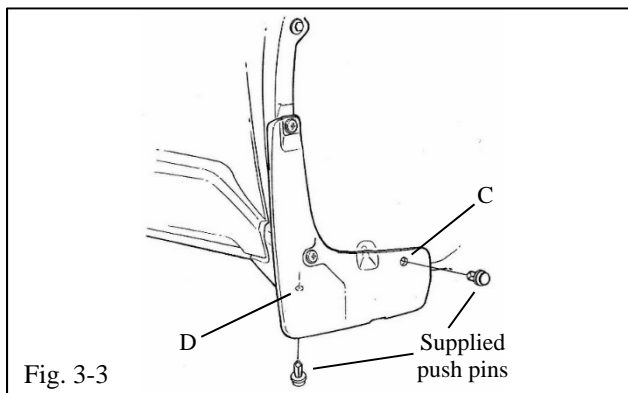

(c) While holding the part up and into body panel, install a supplied push pin in location C, then one in location D (Fig. 3-3).

(d) Repeat Steps 1 through 3 on the other side.

4. Clean the Rear Mounting Area and Remove the Wheel.

+ **NOTE:** DIO installations may require removal and reinstallation of the rear wheels to drill the panel edge and liner attachment holes.

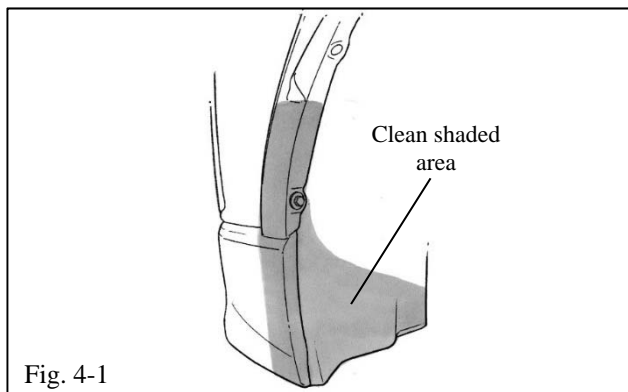

STOP (a) Clean and degrease the rear bumper panel where the mudguard will be located with a clean cloth and soap/water mixture (Fig. 4-1).

(b) **DIO Only:** Support the vehicle and remove the rear wheel. Follow the owner's manual procedure.

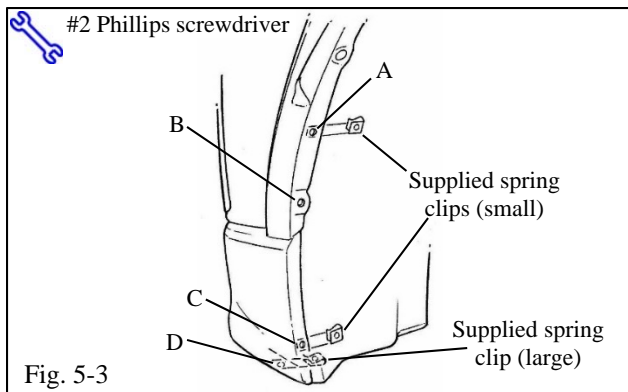
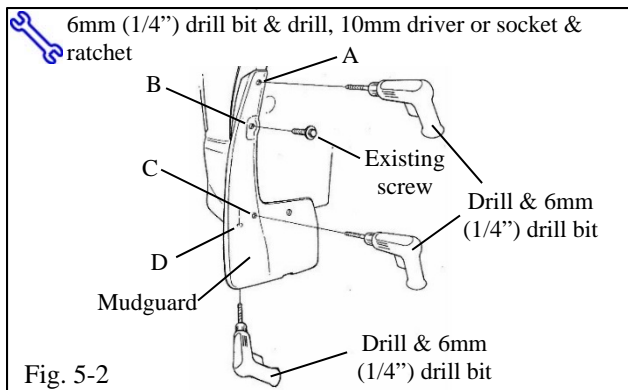
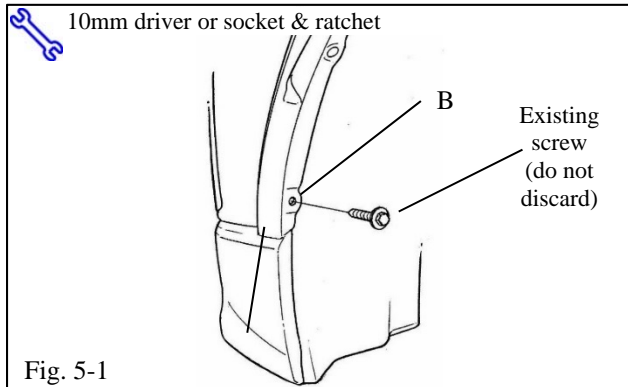

5. Remove and Install the Rear Hardware.

(a) Remove and **RETAIN** the existing screw at location B (Fig. 5-1).

(b) Mount the mudguards and reinstall the existing screw at location B. While holding the part up and into body panel, tighten the screw (Fig. 5-2).

! (c) While holding the part up and into the panel, drill 6mm (1/4") holes in locations A, C then D (Fig. 5-2).

(d) Remove the mudguard and install two supplied spring clips (small) over hole locations A and C with the turned up edge on the inside of the panel (Fig. 5-3).

(e) Install a supplied spring clip (large) over hole location D with the turned up edge on the inside of the panel (Fig. 5-3).

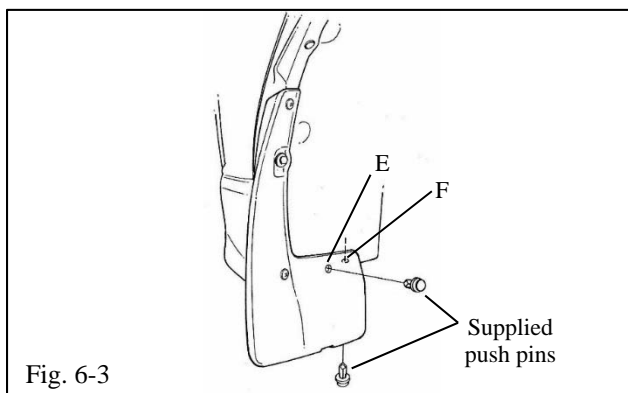
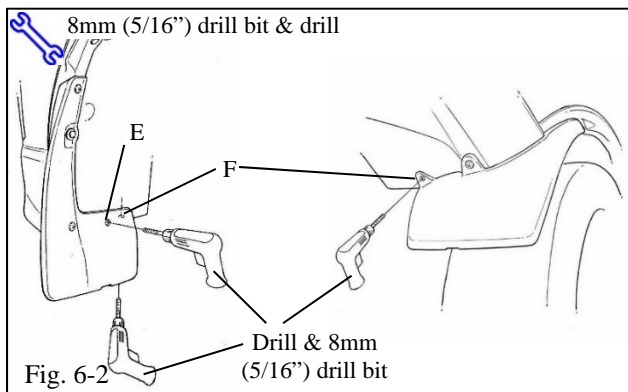
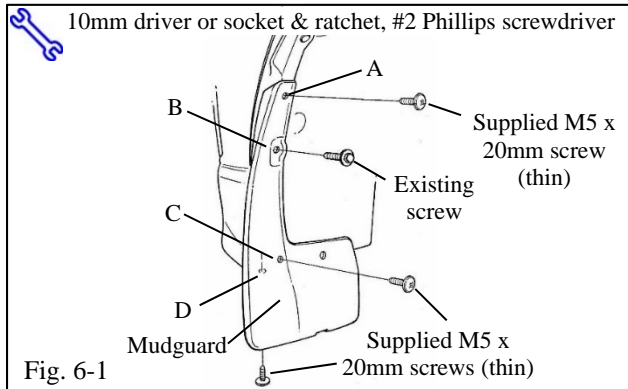

6. Install the Rear Mudguard.

- (a) Hold the part up and into the panel and reinstall the existing screw in location B (Fig. 6-1).
- (b) Hold the part up and into the panel and install a supplied M5 x 20mm (thin) screw in location C, then location A (Fig. 6-1).
- (c) Hold the part up and into the panel and install a supplied M5 x 20mm (thin) screw in location D (Fig. 6-1).



- (d) Hold the part up and into the panel and use the part as a template to drill 8mm (5/16") holes at locations E and F (Fig. 6-2).

- (e) Install supplied push pins at locations E and F (Fig. 6-3).
- (f) Reinstall the rear wheel. Follow the owner's manual procedure.
- (g) Repeat Steps 4 through 6 on the other side.

Checklist - these points **MUST** be checked to ensure a quality installation.

<u>Check:</u>	<u>Look For:</u>
<p><u>Accessory Function Checks</u></p> <ul style="list-style-type: none"><input type="checkbox"/> Gaps between mudguards and body side<input type="checkbox"/><input type="checkbox"/><input type="checkbox"/>	<p>Gaps greater than 1.0 mm</p>
<p><u>Vehicle Function Checks</u></p> <ul style="list-style-type: none"><input type="checkbox"/><input type="checkbox"/><input type="checkbox"/>	
<p><u>Vehicle Appearance Check</u></p> <ul style="list-style-type: none"><input type="checkbox"/> After accessory installation and removal of protective cover(s), perform a visual inspection.	<p>Ensure no damage (including scuffs and scratches) was caused during the installation process. (For PPO installations, refer to TMS Accessory Quality Shipping Standard.)</p>